

CRUSADER CHALLENGER SERIES ENGINES

A DIVISION OF  PLEASURECRAFT ENGINE GROUP

2025 OWNERS Product Technical Specifications

PERFORMANCE TO MOVE YOU

CHALLENGER 5 YEAR TRANSFERABLE LIMITED WARRANTY

Pleasurecraft Marine Engine Co., through its Challenger Series Engines Division ("Challenger"), warrants its new products to be free from defects in material and workmanship under normal use and service conditions. This warranty is extended only to the first registered owner or registered user, as well as all subsequent users who comply with Challenger's warranty transfer policy and receive Challenger's approval of warranty transfer. The obligation of Challenger under this warranty shall be limited to the repair or replacement with new or reconditioned components, at Challenger's option, of any product, or parts thereof, which have failed during the warranty coverage period specified below and are demonstrated upon examination to have failed due to defective material and/or workmanship.

WARRANTY COVERAGE; TRANSFER; WARRANTY PERIOD

This warranty is extended to the first registered owner or registered user purchasing the engine at retail, as well as all subsequent users who, in accordance with Challenger's warranty transfer policy and warranty transfer approval, must notify Challenger within 30 days of any subsequent sale of the product at which time Challenger will review for an approval of the transfer of any remaining portion of warranty coverage. To obtain a Challenger Warranty Transfer Application, contact your local Pleasurecraft dealer or Challenger's Warranty Services Department at (803) 345-1337. Certification of an inspection of the product by an authorized technician and payment of a warranty transfer fee are required to be submitted with the Application.

All components, other than those itemized below and those components that are warranted by Challenger's suppliers, are warranted, solely for non-commercial use, for a period of 5 years or 600 hours of use, whichever first occurs, from the earlier of (1) the date of sale to the first registered owner or registered user, or (2) from the date the engine is first placed into service for demonstration or any other purpose prior to the sale of the engine to the first owner purchasing the engine at retail. Commercial use is defined as, but not limited to, use of the product by ski schools, for promotional use, for athletes' boats, for rentals, etc. In the case of commercial use of the product, the term of this warranty shall be for a period of 5 years or 600 hours of use, whichever first occurs, from the earlier of (1) the date in which the engine is first registered, or (2) within 30 days from the date the boat was manufactured.

Components not covered under this warranty:

- (1) Water pump impellers are not covered by this warranty.
- (2) Seals, gaskets, O-rings, and other materials affected by time are not covered by this warranty if their effectiveness is reduced by an extended storage period prior to sale or use of the product.
- (3) Items such as, but not limited to, lubricants, spark plugs and other items which are frequently replaced as part of routine maintenance.
- (4) Emission Control parts. See Emission Control Warranty Statement.

NO OTHER WARRANTY GIVEN

The obligations set forth in the preceding paragraphs are Challenger's sole obligation and the owner's exclusive remedy. Challenger makes no other express warranty. Any implied warranty of merchantability or fitness for a particular purpose that may be applicable to this product is limited in duration to the duration of this warranty. Some States do not allow limitations on how long an implied warranty lasts, so the above limitation may not apply to you.

No distributor, dealer, agent or employee of Challenger is authorized to grant any other or further warranty or incur any additional warranty obligation on Challenger's behalf in connection with the sale of its products. Any qualification or restriction contained herein which is prohibited by any law of mandatory application shall be deemed to be deleted from this warranty; however, such deletion shall have no effect on the remaining provisions hereof, all of which shall remain in full force and effect.

REMEDIES

The obligation of Challenger set forth in the first paragraph of this warranty shall be the exclusive remedy for any breach of warranty hereunder, and any owner or user's sole remedy in the event of breach of the warranty is repair or replacement of the product or any warranted part thereof as set forth in this warranty. With this sole exception, Challenger shall not be liable for any direct or indirect, incidental or consequential damages, including without limitation, any damages for property damage, loss of use or loss of profits, loss of income, inconvenience, trailering, towing, haul out, launch and/or any other in and out of water expenses, storage charges, dockage charges, expenses to deliver or pick up the product being warranted to and from the dealer, telephone expenses, lodging expenses, travel expenses, mechanic travel time and mileage, damage caused by any occurrence of an insurable nature, rental of substitute equipment of any type, removal and replacement and/or modification of any boat parts to facilitate repairs, moving of furniture, carpets, cleaning, painting, carpenter work, or re-delivery charges. Some States do not allow the exclusion or limitation of incidental or consequential damages, so the above limitation or exclusion may not apply to you.

Any owner or user hereby waives for himself/herself/itself and his/her/its successor and assigns (a) any and all claims for punitive damages, and (b) all claims of negligence or strict liability or both. In no event will Challenger's liability exceed the purchase price of the product(s) which is actually paid to Challenger.

OBTAINING PERFORMANCE UNDER WARRANTY

Challenger's warranty registration form should be prepared by your selling dealer, executed by you and the dealer, and mailed by you to Challenger within 30 days after the date of your purchase of the product. Upon receipt of the warranty registration form, Challenger will issue to you a personalized owner's registration card which will be mailed directly to you. If the owner's registration card is not received within 8 weeks after the date of purchase, please write to Challenger at the address set forth below.

At the time that a claim for warranty service is made, the owner's registration card should be presented to the person or entity providing warranty service. Authorized Challenger dealers or distributors are entitled to be reimbursed by Challenger for some or all of the expense of warranty repairs; thus, service under the terms of this warranty will be performed by an authorized Challenger dealer or distributor without charge for established flat rate labor or replacement parts, other than items not covered by the warranty, such as, but not limited to, water pump impellers, seals, gaskets, O-rings and other materials affected by time if their effectiveness is reduced by an extended storage period prior to sale or use of the product, and lubricants, spark plugs and other items which are frequently replaced as part of routine maintenance. Charges for additional non-warranty work and/or additional dealer charges for labor relative to warranty work in excess of flat rate must be paid for by the owner.

Prior authorization in writing must be obtained from Challenger for any warranty repairs over \$250.00 and in all cases where the owner fails to establish the purchase and warranty expiration dates with the owner's registration card sent upon receipt of the warranty registration form by Challenger. While failure to present the owner's registration card will not prevent you from obtaining coverage hereunder, this warranty shall not be effective and, therefore, cannot be honored until the product purchase date can be confirmed by Challenger. If the card is lost, communicate with Challenger at the address listed below, and, for a processing fee of \$10.00, a new owner's registration card will be issued to you.

Any questions concerning service, parts or this warranty should be directed to your selling dealer. If your dealer is unable to assist or if you relocate, if you are traveling or if you need a referral to your nearest dealer, contact: Pleasurecraft Marine Engine Co., 1737 Highway 76, Little Mountain, SC 29075 (803) 345-1337.

FAILURES EXCLUDED FROM WARRANTY

This warranty will not apply to any failure which results from accidents, sinking, fire, neglect, abuse or abnormal service or use, such as racing, towing or operation in water of insufficient depth, or to any failure resulting from improper installation, improper adjustments, repairs or improper delivery service, or to any failure resulting from the use of parts, fuels, oils or lubricants not suitable for use with the product and/or materials or parts not approved by Challenger. This warranty does not apply to any engine or drive which has been modified, or altered, or repaired in such a manner as, in the opinion of Challenger, to affect its stability, reliability or performance. Further, this warranty will not apply to product failure resulting from (1) use of non-recommended lubricants or fuels, (2) failure to follow maintenance or lubrication schedules, (3) failure caused or contributed to by improper or contaminated fuel, (4) failure caused by water intrusion, salt corrosion to external components, or improper installation or misapplication of the engine or drive, (5) the owner's or operator's failure to exercise due or normal care and precaution, (6) failure of components and/or assemblies that are warranted by Challenger suppliers, and (7) damage resulting from the owner's or operator's failure to timely replace failed water pump impellers, seals, gaskets and O-rings.

OWNER'S RESPONSIBILITY

Performance under this warranty shall be conditioned upon the first registered owner's or registered user's compliance with the following requirements:

- (1) Owner or user shall verify that the pre-delivery service has been performed, all requested information recorded and that the selling dealer has signed the warranty registration.
- (2) Owner or user shall promptly mail the warranty registration to Challenger after accepting delivery.
- (3) Owner or user shall follow the instructions in the owner's manual regarding operation, break-in, lubrication and fuel.
- (4) Owner or user shall follow or comply with the maintenance schedule, operation limits, and lay up instruction, as outlined in the owner's manual. Pleasurecraft original equipment genuine marine engine parts should be used whenever service or repairs are performed.

CHOICE OF LAW

This limited warranty shall be governed by, and construed and interpreted in accordance with, the local laws of the State of Ohio (without application of its conflicts of laws principles), except only to the extent replaced or precluded by other law of mandatory application.

GENERAL

This warranty gives you specific legal rights, and you may also have other rights which vary from State to State.

The Challenger Federal/California Emissions Warranty and Federal/California Emissions Control Warranty Statement are separate documents included in the owner's manual. Any questions concerning the Emissions Warranty can be obtained by calling Challenger at (803) 345-1337.

Challenger's policy is one of continued improvement of its products, and Challenger hereby reserves the right to improve and change the design and production of any of its products without assuming any obligation to modify products previously manufactured and/or sold.

CRUSADER CHALLENGER WARRANTY TRANSFER APPLICATION

The remainder of the warranty coverage period of the original Challenger Series Engines ("Challenger") limited warranty is transferable within thirty (30) days of date of sale by the original owner/user to a subsequent purchaser for the remainder of the unused portion of the original warranty coverage period, or the remainder of 300 hours of use, whichever first occurs. The original date of sale or original in-service date (whichever comes first) begins the warranty coverage period. For commercial use such as, but not limited to, use of the product by ski schools, for promotional use, for athletes' boats, for rentals, etc., the warranty coverage period starts from the earlier of (1) the date in which the engine is first registered, or (2) within 30 days from the date the boat was manufactured.

Direct Sale by Authorized Challenger Marine Dealer:

If the sale is conducted through an authorized Challenger Marine dealer, the dealer must complete and submit the Challenger Warranty Transfer Application, the required engine photographs, Diacom recording and warranty transfer fee. The warranty transfer application will be processed based on the approval of Challenger. This inspection will be at the seller or purchaser's expense.

Sale by Private Individual / Non-Authorized Dealer:

If the sale is conducted between private individuals, or between a private individual and an unauthorized Challenger Marine dealer, the engine/drivetrain must be inspected by an authorized Challenger Marine dealer. This inspection will be at the seller or purchaser's expense. The dealer must complete and submit the Warranty Transfer Application, the required engine photographs, Diacom recording and warranty transfer fee. The warranty transfer will be processed based on the approval of Challenger.

The fee for warranty transfer is \$400. The transfer fee (via certified check) and Warranty Transfer Application must be submitted to Challenger within 30 days of date of sale to:

Pleasurecraft Engine Group
1737 Highway 76
Little Mountain, S.C., 29075

- The new owner will be notified within 10 days of Challenger's receipt of the Warranty Transfer Application form regarding whether the transfer has been approved by Challenger. If the transfer is approved, the warranty expiration date will be provided.
- A Warranty Registration Card will be issued to the second owner, reflecting the change has been made in Challenger's computer.

OUTSIDE THE U.S. AND CANADA, CONTACT YOUR LOCAL PLEASURECRAFT DEALER OR CHALLENGER WARRANTY SERVICES AT (803) 345-1337 FOR MORE INFORMATION ON HOW TO APPLY FOR A WARRANTY TRANSFER.

IMPORTANT! PURCHASER NOTICE: The inspection below is designed to insure safety and satisfaction. Therefore, we require the following inspection to be performed at your expense, by an authorized Challenger technician, prior to purchase. By signing below, the technician certifies that he/she has checked the installation and operation of the engine and finds it to be performing properly. All terms in the Limited Warranty located in the Engine Owner's Manual still apply.

ENGINE MODEL: _____	ENGINE SERIAL: _____
TRANS. SERIAL: _____	ENGINE HOURS: _____
HULL SERIAL #: _____	BOAT MANUFACTURED DATE: _____
INSPECTION DATE: _____	

Warranty Transfer Inspection

- | | | |
|---|---|--|
| <input type="checkbox"/> Check for Bulletins | <input type="checkbox"/> Trouble Codes Checked
Trouble Codes Cleared | <input type="checkbox"/> Belt and Pulley: Inspect for Damage |
| <input type="checkbox"/> Engine Oil: Check | <input type="checkbox"/> All Fuel Lines: Confirm No Leaks | <input type="checkbox"/> Exhaust Hoses/Clamps: Inspect |
| <input type="checkbox"/> VDrive Lube: Check | <input type="checkbox"/> All Oil Lines: Confirm No Leaks | <input type="checkbox"/> Record Propeller Size and Rotation
Diameter _____ Pitch _____ Rotation _____ |
| <input type="checkbox"/> Transmission Fluid: Check | <input type="checkbox"/> All Water Lines: Confirm No Leaks | <input type="checkbox"/> Engine Compression
Cylinder 1 _____ Cylinder 2 _____ |
| <input type="checkbox"/> Propshaft Alignment | <input type="checkbox"/> All Drain Plugs: Confirm
Proper Installation | Cylinder 3 _____ Cylinder 4 _____ |
| <input type="checkbox"/> Battery Rating, Charge, and
Level: Check | | Cylinder 5 _____ Cylinder 6 _____ |
| <input type="checkbox"/> Diacom Recording:
Ignition ON, Engine OFF Recording
(submit with application) | <input type="checkbox"/> (3) Engine Photos:
Include engine top, port and starboard (photos must be clear and in good light) | Cylinder 7 _____ Cylinder 8 _____ |

I hereby certify the warranty transfer inspection on engine S/N _____ and have corrected any abnormality revealed by this inspection.

_____ (Technician signature, Dealer & Date)	_____ (Seller's Signature and Date)	_____ (Purchaser's Signature and Date)
DATE OF SALE (2ND Owner) ____/____/____	DATE OF SALE (1st Owner/1st Operator) ____/____/____	
(New Owner) NAME: _____	(Previous Owner) NAME: _____	
ADDRESS: _____	ADDRESS: _____	
CITY, STATE, ZIP: _____	CITY, STATE, ZIP: _____	
EMAIL ADDRESS: _____		

By checking this box, you are authorizing Challenger to send the email address to receive emails whenever a product bulletin or safety recall affects this product.

Engine Serial Number and Specification Decal Locations



1. ENGINE SPECIFICATION DECAL



2. ENGINE IDENTIFICATION DECAL

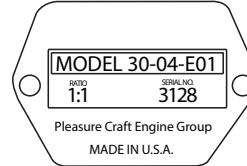

3. TRANSMISSION IDENTIFICATION PLATE

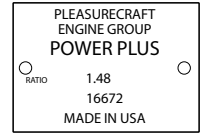

4. VDRIVE IDENTIFICATION PLATE

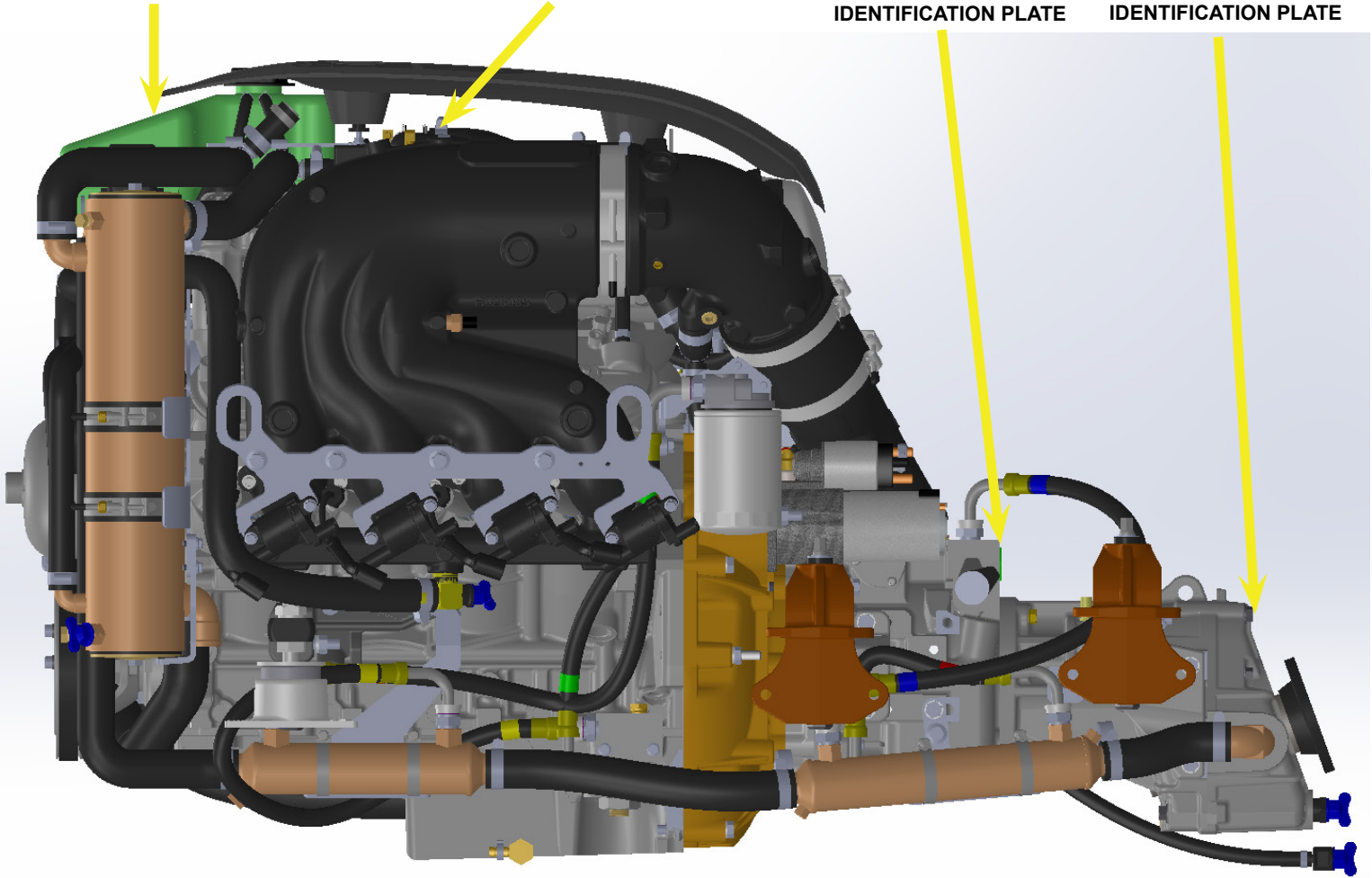

ENGINE RPM CHART

Model	Minimum Full Load	Preferred	Maximum
6.0L CES / 6.0L HO CES	5400	5500	5600

IMPORTANT

Your new Pleasurecraft Marine engine incorporates an RPM "MAX GOVERNOR" in order to prevent the engine from over-revving. Operation above the Maximum RPM is not recommended. If your engine is operating above the maximum RPM listed, a higher pitched propeller would be required to lower the engine maximum RPM to the Preferred RPM.

CAUTION

Prolonged WOT operation will shorten the life of your engine and could cause premature engine failure. Problems caused by prolonged WOT operation are considered abuse and are not covered under the Pleasurecraft Marine Warranty.

Engine and Transmission Fluid Capacities

ENGINE FLUID CAPACITIES

Model	ALL MODELS
Crankcase Oil Capacity W / NEW FILTER	Start with 4 Quarts (3.7L) ¹
Fresh Water Cooling System Capacity	Fill Until Completely Purged ³

Engine Oil Requirements

Prevailing Ambient Temperature	Recommended A.P.I. Classification & Viscosity
All Temperatures	DEXOS GEN 2 5W-30

These engines require the use of SAE 5W-30 DEXOS 1 GEN 2 formula oil. These engines must be serviced with this weight and formula engine oil.

These engines are designed specifically with use of DEXOS 1 GEN 2 formula engine oil. This formulation is now found in most major brands of engine oil.

WARRANTY NOTICE: PCM Engines reserves the right to refuse warranty on part(s) and/or engine(s) damaged by using improper fuels and engine oils.

- Crankcase oil and oil filter change - Recommended intervals:
 - Initial oil change - This engine starts out with break-in oil and should be run in the engine for at least the first 5 hours of operation. Any time after 5 hours, but NO MORE than 25 hours, the engine oil and filter must be changed.
 - Regular oil changes - Every 50 hours of operation or once a year.
 - Heavy Duty High RPM / High Load Use - Every 30 hours of operation or once a year.

NOTE: Never over-fill the engine with oil. Engines over-filled with oil can cause engine damage.

TRANSMISSION FLUID CAPACITIES

Model	All Models	Type
PCM, 1:1 Ratio ^{1,2,4}	2.0 Quarts (1.9L)	DEXRON III
PCM, 1.23:1 Ratio ^{1,2,4}	2.0 Quarts (1.9L)	DEXRON III
Pleasurecraft V-Drive, All Ratios ^{1,2,5}	1.5 Quarts (1.42L)	PowerPlus V-Drive Lubricant Pleasurecraft Marine P/N - R190251

- 1 - **Engine Fluid Capacities are dependent on installation angle. DO NOT** overfill the crankcase or transmission. Remove excess fluid above the "FULL" mark on the dipstick. Check oil with the boat at its normal, level, at rest position on the water. Ensure that ballast systems (if equipped) and excess water in the bilge have been purged. If the boat is on a trailer, the trailer must be level and adjusted to represent the boat's normal resting state on the water. Oil capacities are approximate, and may not include capacity needed for transmission cooler and oil lines. Refer to the **Checking Fluid Levels** instructions and **Changing Oils** instructions of this manual, for complete instructions, important notes and Cautions for checking engine oil levels. Always use the dipstick to determine the exact quantity of oil required. Add the correct amount of oil to fill to the "FULL" mark on the oil level dipstick.
- 2 - **IMPORTANT:** 80 Series PCM 1:1, 1.23:1 and all other transmission fluid levels are checked at operating temperature and immediately after shutdown of the engine.
- 3 - Fresh Water Cooling systems vary depending on half-systems, full-fresh systems, heaters, hose lengths, etc. System should be completely purged of air and the coolant level should be within the MIN/MAX level of the degas bottle after the engine has been ran at operating temperature and the system is allowed to cool down overnight. Top off as necessary.
- 4 - All Pleasurecraft Marine transmissions - Use Dexron III automatic transmission fluid - Inspect fluid level after the first 25 hours of use and every 100 hours, or annually, thereafter. Fluid should only be changed every 250 hours, or if evidence of contamination is present.
- 5 - All Pleasurecraft Marine Power-Plus V-Drive Gear - Change fluid level after the first 25 hours of use. Inspect fluid every 100 hours, or annually, thereafter. Fluid should only be changed every 600 hours, or if evidence of contamination is present. Use Pleasurecraft Marine P/N: R190251.

Specifications

MASTER ENGINE SPECIFICATIONS

MODEL	6.0L / 6.0L HO
Displacement	6.0L (366 CID)
Bore	4.0007 in. (101.618 mm)
Stroke	3.622 in. (92.0 mm)
Compression Ratio	9.67:1
Compression	130 - 215 psi
WOT Operating RPM Preferred WOT RPM	5400 - 5600 5600
Cruising RPM (Max)	4480
Idle RPM	650 (Not Adjustable)
Oil Pressure @ 2000 RPM	25 - 80 psi (172 - 552 kPa)
Minimum Oil Pressure	5 psi (35 kPa) - Idle 24 psi (165 kPa) - 4000 RPM
FCC Fuel Pressure (wide open throttle)	57 - 62 psi (393 - 427 kPa)
Spark Plug P/N Spark Plug Gap	R030011 0.040 in.
Firing Order	1-8-7-2-6-5-4-3
Thermostat	160°F (61.7°C)
Engine Over- Temperature	200° F (93.3° C)
Exhaust Cooling System Over- Temperature	Temperature Varies based on Engine Speed Engine Derates
Electrical System	12 Volt Negative (-) Ground
Alternator Rating	120 Amps
Battery Rating	650 CCA (Minimum) 120 Ah

NOTE: FOR NEW BOAT PROPPING, IT IS RECOMMENDED THAT OEMS PROP TO THE MAXIMUM RPM LISTED.

IMPORTANT: FUEL PRESSURE VALIDATION MUST BE MADE WITH THE ENGINE UNDER LOAD.

**LH ROTATION
FRONT**

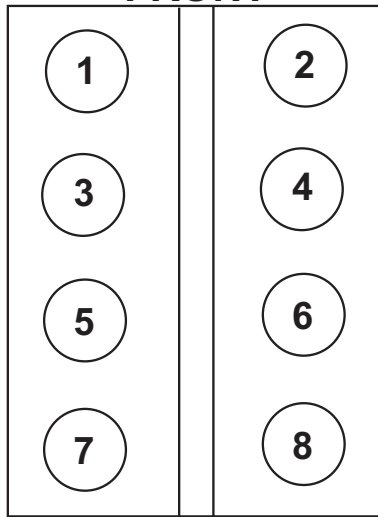

**NO
DISTRIBUTOR**

**FLYWHEEL END OF ENGINE
ALL V-8 MODELS**

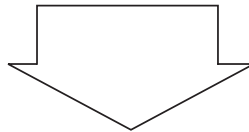

**FIRING ORDER:
1-8-7-2-6-5-4-3**

TUNE-UP SPECIFICATIONS

Model	6.0L / 6.0L HO
Spark Plug Type	R030011
Spark Plug Gap	0.040 in (1.02 mm)
Ignition Timing	Fixed, Not Adjustable
Firing Order	1-8-7-2-6-5-4-3 (LH Rotation)
CAM Retard	Not Adjustable

ACCESSORY DRIVE BELT

Challenger engines use a single serpentine belt to drive the engine water circulation pump, sea-water pump and the alternator.

WARNING

Engine must be shut OFF and the ignition key removed before inspecting the drive belt(s). The drive belt(s) should be checked periodically for condition and tension. If the belt(s) shows signs of cracking, glazing or deterioration, replace with new belt(s).

DRIVE BELT INSPECTION

Inspect the drive belt for excessive wear, shredding or missing sections.

Inspect the drive belt for contamination from excessive dirt, oil, coolant or other substances that may effect the drive belt operation.

If a problem is found, replace the belt after inspecting the following items:

- All pulleys and tensioners for signs of misalignment
- All pulleys and tensioners for signs of rust or other damage
- Bent pulleys or tight bearings in the engine water circulation pump, sea-water pump and alternator

DRIVE BELT REPLACEMENT

6.0L / 6.0L HO BELT #: R066033

1. Note the routing of the belt before removing.
2. Using a 15 mm box wrench or socket, turn the belt tensioner to relieve the tension on the belt. Slide the belt off of the pulleys. **Release the tensioner slowly to prevent the tensioner from snapping against its stop, and possibly causing damage to the tensioner.**
3. Slide the new belt onto the pulleys using the same routing as noted prior to removal.
4. Compress the belt tensioner, and slide the belt over the tensioner pulley. Release the tension slowly to tension the belt.

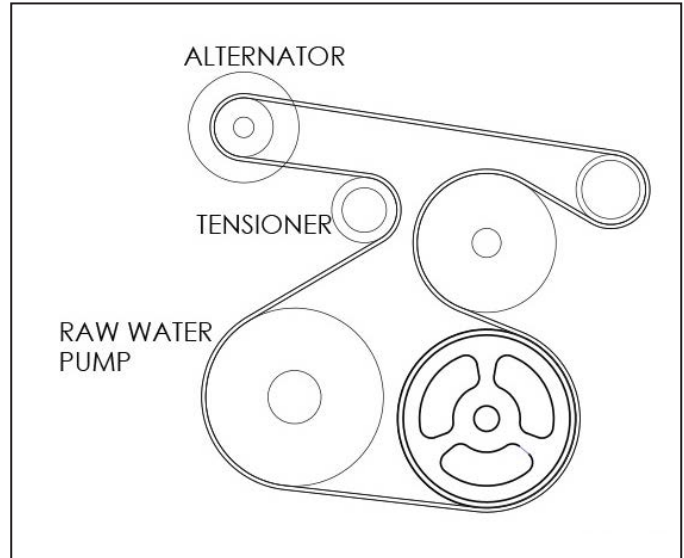

6.0L Accessory Drive Belt Configuration

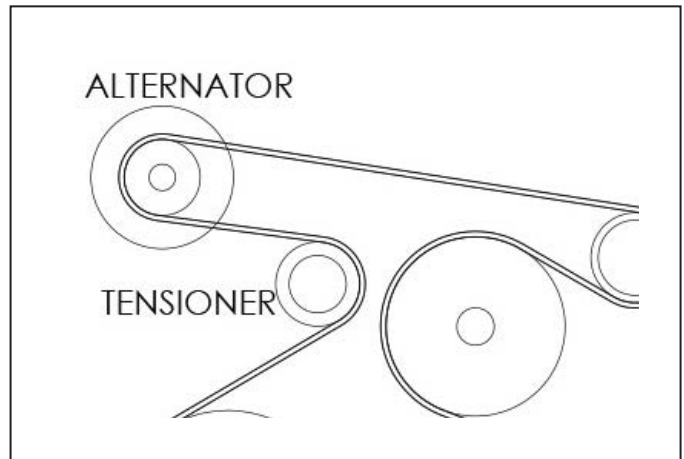

6.0L Belt Tensioner

SERVICING RAW WATER PUMP IMPELLER

IMPELLER KIT #: RP061022

The raw water pump impeller should be serviced every 50 hours, or once a year, whichever occurs first. See Maintenance Schedule.

Locations "A" are access holes in order to loosen the raw water pump attaching bolts. The bolts are secured in the pump by O-rings, and will not fall out during removal.

Torque the raw water pump housing attaching bolts to 8.5-9 ft.lbs. (11.5-12 N-M), when re-installing the impeller.

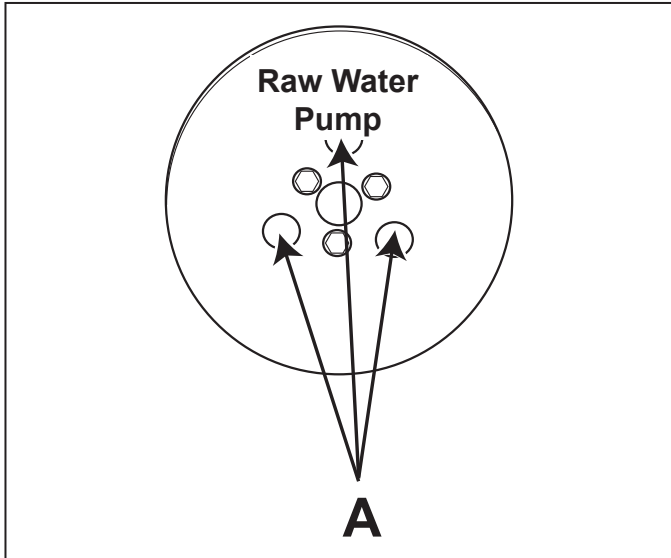

Raw Water Pump Impeller Bolt Locations "A"

Cooling System Drain Locations

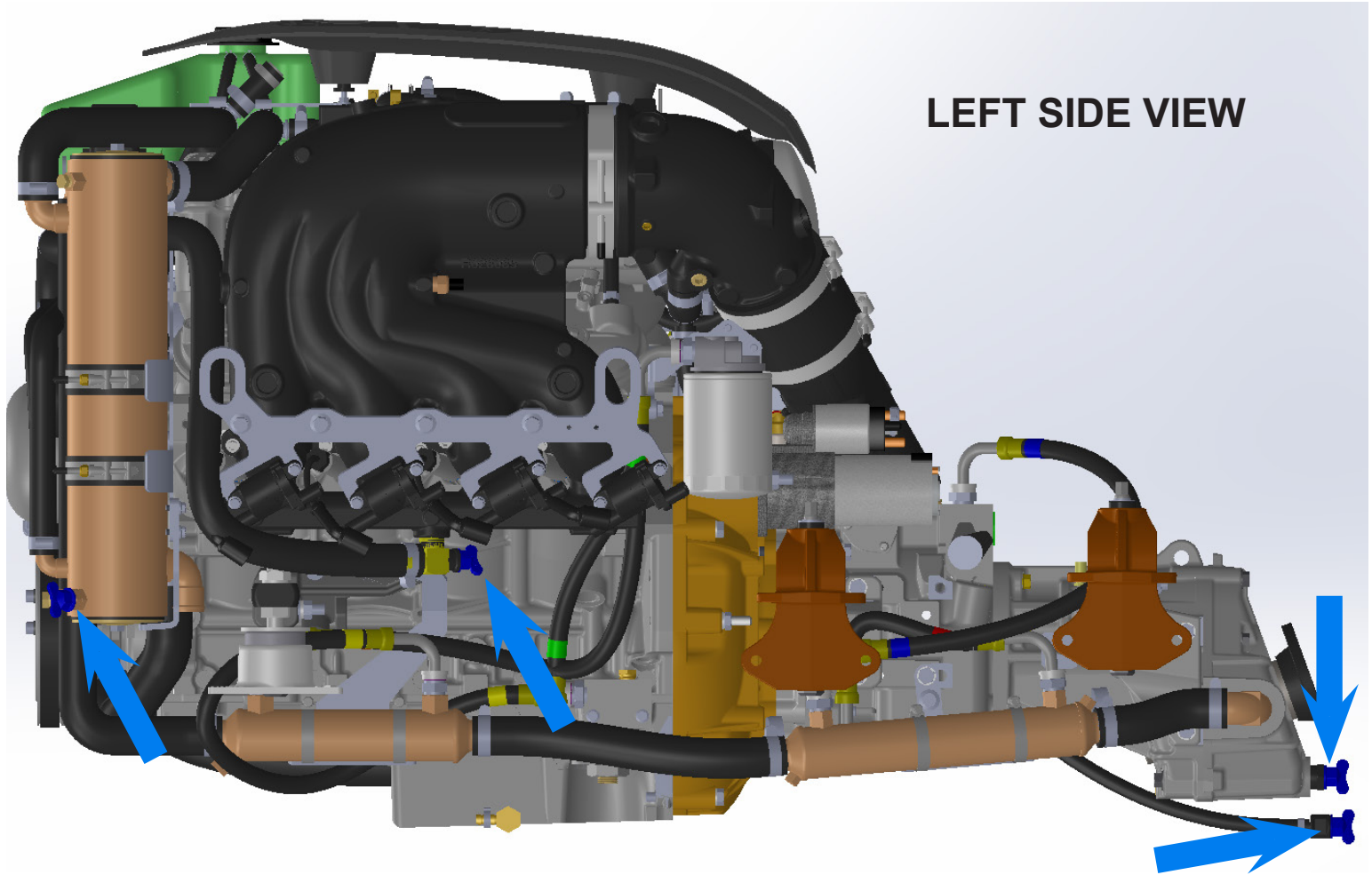

Remove the (5) BLUE screw in drain plugs from the following locations:

- (2) One on bottom center of each manifold
- (1) Heat Exchanger
- (1) Rear of VDrive
- (1) Remote Hose for Exhaust Crossover

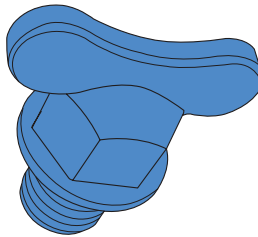

IMPORTANT: Refer to both illustrations to identify all 5 drain locations. Ensure each location completely drains.

RIGHT SIDE VIEW

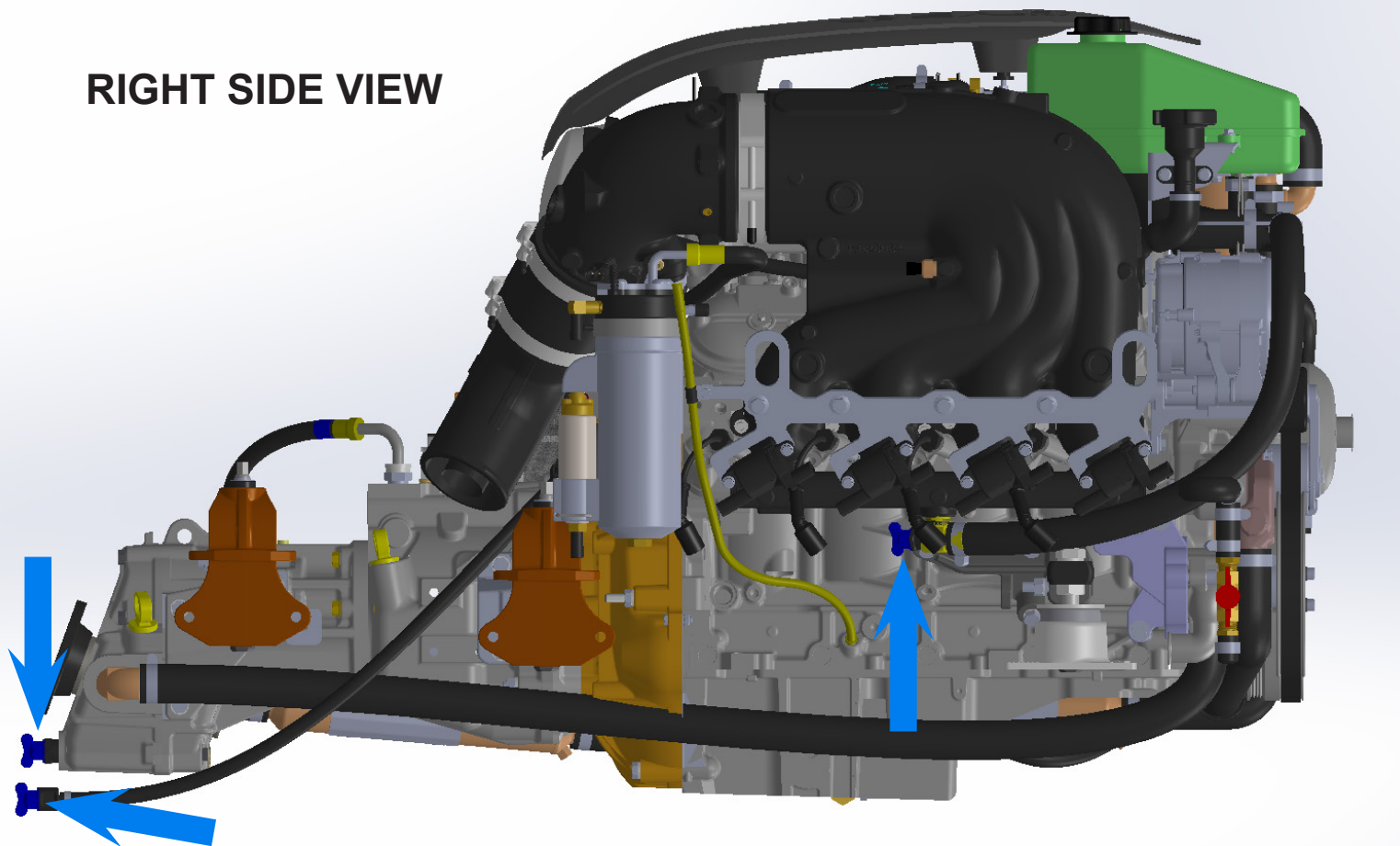

COOLING SYSTEM SACRIFICIAL ANODES

Located in the raw water side of the cooling system are sacrificial anodes which are marked by a decal. To check, remove the anode and visually check the condition of the rod. The length of the anode rod when new is approximately 1.5 inches. If more than one half of the anode is gone, replace with a new sacrificial anode.

Different geographic locations and water make-up can result in either high or low sacrificial requirements. A high rate of sacrificial anode consumption should also alert the owner to a possibility of an improperly wired boat accessory, which would require complete checking by qualified service personnel.

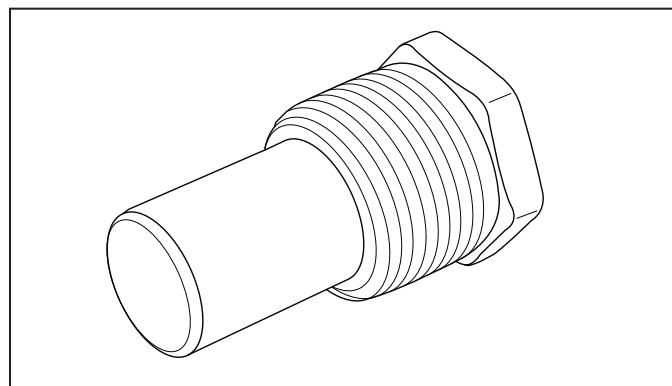

Typical Sacrificial Anode

CHALLENGER Closed Cooling Applications

- One anode is in the heat exchanger raw water drain location.
- One anode is in the rear of the Vdrive Housing for a drain. (Coastal applications)

Heater Connection Locations

6.0L / 6.0L HO Applications

NOTE: Pre-fill the heater hoses and heater core prior to connecting the heater hoses to the engine. This reduces the amount of air that must be purged from the system for proper cooling operation.

